

CAPACITY	SYMBOL/ SERIAL NO.	
AC100V-254V, 50/60Hz		
18W x 2		

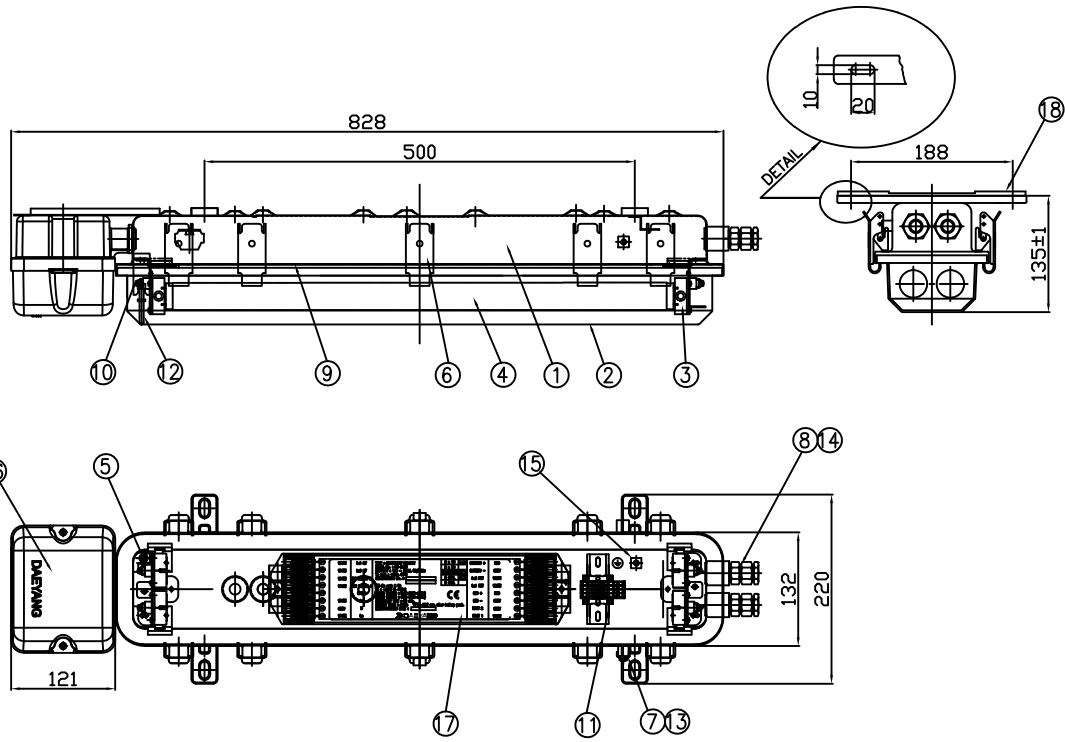

-NOTE-

1. EMERGENCY DURATION : 3 hours
2. FULL CHARGING TIME : 32 hours
3. 1-LAMP OPERATION
4. AFTER LIGHTING IS INSTALLED,
PLEASE ROTATE BATTERY BOX COVER AND ASSEMBLE FOR WIRING CONNECTION.
5. WHEN THE CONTINUOUS POWER IS NOT SUPPLIED,
CONNECTOR SHOULD BE DISCONNECTED TO AVOID NATURAL DISCHARGE OF BATTERY.

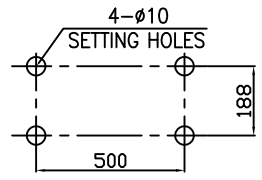

SETTING DIMENSION

18	ANTI-VIBRATION PACKING	IIR	2		9	REFLECTOR	STEEL	1	
17	EMERGENCY BALLAST	-	1	EX-Bu20	8	GLAND HUB(M20)	STAINLESS STEEL316	2	
16	BATTERY CASE	-	1		7	OUTSIDE EARTH BAR	STAINLESS STEEL316	1	M6
15	INSIDE EARTH BAR	STAINLESS STEEL316	1		6	LATCH	STAINLESS STEEL316L	10	
14	CABLE GLAND(M20)	BRASS	2	OS-E1UF 16 (9~15.5mm)	5	BATTERY CHARGE LED	ASSEMBLY	1	
13	EARTH BOLT	STAINLESS STEEL316	1		4	LAMP	-	2	OSRAM LUMILUX T8
12	INTERLOCK SHAFT	BRASS	1		3	LAMP HOLDER	ASSEMBLY	4	
11	TERMINAL BLOCK	-	1	5P	2	GLOBE	POLYCAR-BONATE	1	
10	INTERLOCK SWITCH	-	1		1	BODY	STAINLESS STEEL316L	1	
NO.	NAME OF PARTS	MATERIAL	Q'TY	REMARKS	NO.	NAME OF PARTS	MATERIAL	Q'TY	REMARKS

APPROVED	B. K. KIM	UNIT	MM	TITLE; INCREASED SAFETY FLUORESCENT LIGHT W/BATTERY BACKUP (Ex db eb mb IIC T4 Gb) FOR MARINE USE
CHECKED		SCALE	N/S	
DRAWING	B. I. KIM	COLOR	N-9.3	
DATE	2015.12.04	IP	67	



MODEL NO.	FL-220edgBu-550UWM16UF2H(5P)	WEIGHT	6.4 Kg
DWG NO.	L71170093	SHEET NO.	89

-NOTE-

* INDICATION LAMP COLOR STATUS

NO	LED		MODE
	GREEN	RED	
1	Steady	-	Fully charged
2	Fast flash 1sec on, 1sec off	-	Charging
3	-	Fast flash 0.5sec on, 0.5sec off	Emergency mode
4	-	Periodic shor flash three times per 4secs	End of lifetime of emergency lamp
5	-	Periodic shor flash twice per 4secs	Battery defects
6	-	Periodic shor flash once per 4secs	ext sw is open
7	-	-	Signal defects or battery discharged

NO	CONTENT	DATE	REVISER	APPROVAL
△				
△				
△				

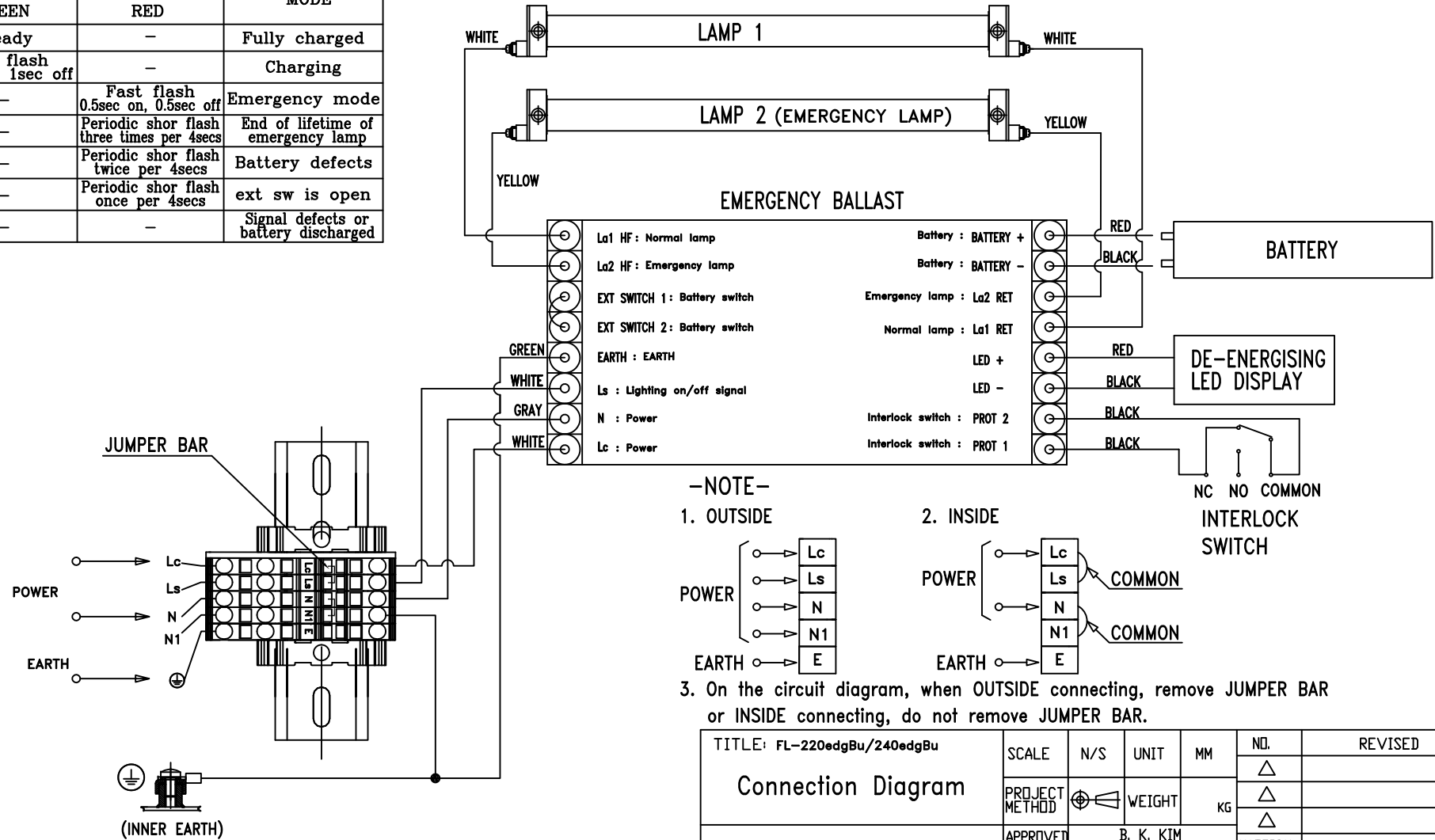

-NOTE-

1. OUTSIDE
2. INSIDE
3. On the circuit diagram, when OUTSIDE connecting, remove JUMPER BAR or INSIDE connecting, do not remove JUMPER BAR.

TITLE: FL-220edgBu/240edgBu				SCALE	N/S	UNIT	MM	NO.	REVISED
Connection Diagram				PROJECT METHOD	⊕	WEIGHT	KG	△	
				APPROVED	B. K. KIM			MATERIAL	ASS'Y
				CHECKED	O. J. KWON			DWG NO.	
DAEYANG				DRAWN	B. I. KIM			SHEET NO.	89-B
				DATE	2015.12.04				

OS-E1UF

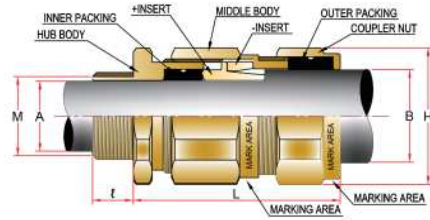

Application : Any Type of Armoured Cable

- For use with any type of armoured cable
- Outdoor & Indoor use
- Flameproof & Increased Safety
- EMC cable gland. (360 ° contact) - EMC tested
- Reduce the effect of coldflow characteristics
- Double compression

Design Specification	BS 6121, IEC 62444, EN 50262
Compliance Standard	IEC/EN 60079-0, 1, 7, 31
ATEX Certification	Presafe 17 ATEX 11456X
IECEx Certification	IECEx PRE 17.0063X
Code of Protection	II2G Ex db IIC Gb, Ex eb IIC Gb, II2D Ex tb IIIC Db
Operating Temperature	-60°C ~ 110°C
Regulation	Zone 1, 2, 21&22, Gas Group IIA, IIB and IIC
Ingress Protection	IP 66 / 67 IP68 available when requested only
Applicable Cable Specification	All types of armoured cable
Gland Material	Nickel plated brass(standard), Brass(only), Stainless steel(316L), Aluminum
Gasket (washer)	Nylon(Standard), PTFE-Teflon(Option)
Packing	Silicone
Accessories (optional)	Lock nut, Sealing washer, Earth tag, Shroud, Serrated washer

Order Example

Part No.	Thread	Material	Accessories
OS-E1UF 20	M20	Nickel plated brass	Lock nut, Sealing washer, Earth tag, Serrated washer, Shroud

- Optional Thread Length : ≥15mm (Standard : M16 ~ M63 Length 15mm, M75 Length 20mm, M90 ~ M115 Length 25mm)
- Material for accessories is required

BS 6121 Type of Gland (The suffix for each type of protection)

Type	Suffix	Position
Single wire armoured	W	Wire armoured
Wire braided	X	Braid armoured
Aluminium strip armoured	Y	
Double steel tape armoured	Z	



Part No.	Entry Thread Size(M)			Minimum Thread Length(ℓ)			Cable Dia		Armour Size		Hexagon Dimensions	Weight (g)	Length (L)
	Metric	NPT	Option	Metric	NPT	Option	Inner 'A'	Outer 'B'	Wire	Braid			
OS-E1UF 16	M16	1/2"	M20	15	15	15	5.0 ~ 11.5	9.0 ~ 15.5	0.9 ~ 1.25	0.05 ~ 0.8	H25 x P27	137	56
OS-E1UF 20	M20	1/2"	3/4"	15	15	16	7.5 ~ 15.2	14.0 ~ 20.5	0.9 ~ 1.25	0.05 ~ 0.8	H31 x P34	212	63
OS-E1UF 25	M25	3/4"	1"	15	16	18	13.0 ~ 19.6	17.0 ~ 26.0	1.25 ~ 1.6	0.05 ~ 0.8	H37 x P40	325	68
OS-E1UF 32	M32	1"	1-1/4"	15	18	19	16.5 ~ 26.2	24.0 ~ 33.5	1.6 ~ 2.0	0.05 ~ 1.2	H47 x P50	570	75
OS-E1UF 40	M40	1-1/4"	1-1/2"	15	19	21	23.0 ~ 32.3	30.0 ~ 41.5	1.6 ~ 2.0	0.05 ~ 1.2	H56 x P60	876	83
OS-E1UF 50	M50	1-1/2"	2"	15	21	24	29.0 ~ 41.5	38.0 ~ 50.0	1.8 ~ 2.5	0.05 ~ 1.2	H70 x P75	1445	89
OS-E1UF 63	M63	2"		15	24		39.0 ~ 50.0	45.0 ~ 60.0	1.8 ~ 2.5	0.05 ~ 1.2	H77 x P82	1740	98
OS-E1UF 63X	M63		2-1/2"	15		27	46.0 ~ 55.0	55.0 ~ 66.0	1.8 ~ 2.5	0.05 ~ 1.2	H82 x P88	1907	98
OS-E1UF 75	M75	2-1/2"		20	27		52.0 ~ 61.0	58.0 ~ 72.0	1.8 ~ 2.5	0.05 ~ 1.2	H92 x P100	3270	109
OS-E1UF 75X	M75		3"	20		30	59.0 ~ 67.0	66.1 ~ 79.0	1.8 ~ 2.5	0.05 ~ 1.2	H98 x P106	2912	109
OS-E1UF 90	M90	3"	3-1/2"	25	30	32	66.0 ~ 80.0	72.0 ~ 90.0	1.8 ~ 3.0	0.05 ~ 1.6	H110 x P120	4600	111
OS-E1UF 100	M100	3-1/2"	4"	25	32	32	76.0 ~ 90.5	84.0 ~ 101.5	1.8 ~ 3.0	0.05 ~ 1.6	H125 x P135	5500	123
OS-E1UF 115	M115	4"		25	32		88.0 ~ 102	100 ~ 116	1.8 ~ 3.0	0.05 ~ 1.6	H135 x P143	5500	123

※ The entry holes need not greater than 0.7mm

※ Up to M75, 1.5 pitch is standard and from M90, 2.0 pitch is standard